

FICHE D'HOMOLOGATION / HOMOLOGATION FORM





033-EM-01



COMMISSION
INTERNATIONALE
DE KARTING - FIA



MOTEUR / ENGINE MINI

Constructeur / <i>Manufacturer</i>	LENZOKART SRL
Marque / <i>Make</i>	LKE
Modèle / <i>Model</i>	R16
Catégorie / <i>Categorie</i>	Group 3
Durée de l'homologation / <i>Validity of the Homologation</i>	3 ans / 3 years
Nombre de pages / <i>Number of pages</i>	14
La présente Fiche d'Homologation reproduit descriptions, illustrations et dimensions du moteur au moment de l'homologation CIK-FIA.	<i>This Homologation Form reproduces descriptions, illustrations and dimensions of the engine at the moment of the CIK-FIA homologation.</i>
	
Photo du moteur côté pignon / <i>Photo of engine drive side</i>	Photo du moteur côté opposé / <i>Photo of engine opposite side</i>
Signature et tampon de l'ASN / <i>Signature and stamp of the ASN</i>	Signature et tampon de la CIK-FIA / <i>Signature and stamp of the CIK-FIA</i>
	

INFORMATIONS TECHNIQUES / TECHNICAL INFORMATION

A Caractéristiques / Characteristics

Le nombre de décimales doit être de 2 ou en accord avec la tolérance appliquée. / The number of decimal places must be 2 or comply with the relevant tolerance.	Tolérances et remarques / Tolerances & remarks	
Cylindre / Cylinder		
Volume du cylindre / <i>Cylinder volume</i>	59 cm³	< 60 cm ³
Alésage d'origine / <i>Original bore</i>	41.80 mm	--
Alésage théorique maximum / <i>Maximum theoretical bore</i>	< 42.10 mm	
Course / <i>Stroke</i>	43.0 mm	±0.1 mm
Vilebrequin / Crankshaft		
Nombre de lumières d'admission / <i>Number of intake ports</i>	1	--
Largeur des lumières d'admission* / <i>Width of intake ports*</i>	26.0 mm	+0.1/-0.2 mm
Nombre de conduits/lumières de transfert, cylindre/carter / <i>Number of transfer ports/ducts, cylinder/sump</i>	2	--
Largeur des lumières de transfert* / <i>Width of transfer ports*</i>	24.9 mm	+0.4/-0.2 mm
Nombre de lumières d'échappement / <i>Number of exhaust ports</i>	1	--
Largeur des lumières d'échappement* / <i>Width of exhaust ports*</i>	28.0 mm	+0.1/-0.2 mm
Forme de la chambre de combustion / <i>Shape of combustion chamber</i>	Gabarit / <i>Template CIK</i>	
Bielle / Conrod		
Poids du vilebrequin complet, sans piston / <i>Weight of crankshaft complete, without piston</i>	1181 gr.	±3 % total
Dimensions des paliers / <i>Dimensions of bearings</i>	17x40x12	en/in mm
Type des paliers / <i>Type of bearings</i>	Roulement a rouleaux / <i>Roller bearing</i>	
Piston / Piston		
Longueur (entre-axe) de la bielle / <i>Length between the axes of the conrod</i>	88.0 mm	±0.1 mm
Diamètre de la tête de bielle / <i>Diameter of big end</i>	22 mm	±0.05 mm
Diamètre du pied de bielle / <i>Diameter of small end</i>	13 mm	±0.05 mm
Poids de la bielle / <i>Weight of conrod</i>	49 gr.	minimum
Piston / Piston		
Nombre de segments du piston / <i>Number of piston rings</i>	1	--
Poids du piston, segments du piston inclus / <i>Weight of the piston including piston rings</i>	57 gr.	±10 % total
Taille de l'axe de piston / <i>Size of gudgeon pin</i>	34.5x10 mm	±0.8 mm
Poids de l'axe de piston / <i>Weight of gudgeon pin</i>	10.7 gr.	±10 % total

* Toutes les dimensions peuvent être vérifiées à l'aide du gabarit du constructeur / *All dimensions can be checked using the manufacturer's template*

B	Angles d'ouverture / Opening angles		
	Lumière d'admission / Intake port	144.0°	+0 / -2°
	Lumière de transfert / Transfer port	114.0°	+0 / -2°
	Lumière d'échappement / Exhaust port	156.0°	+0 / -2°

C	Matériau / Material	
	Culasse / Cylinder head	ALUMINIUM ALLOY
	Cylindre / Cylinder	ALUMINIUM ALLOY
	Carter / Sump	ALUMINIUM ALLOY
	Vilebrequin / Crankshaft	STEEL / Coating: --
	Bielle / Connecting rod	STEEL / Coating: --
	Piston / Piston	ALUMINIUM ALLOY

D	Embrayage / Clutch		
	Poids de l'embrayage assemblé / Weight of the clutch assembly	730 gr.	minimum
	Dimensions de l'embrayage / Dimensions of the clutch	selon dessin technique n°3.4 / according to technical drawing no. 3.4	
	Poids de l'embrayage / Weight of the clutch	345 gr.	±15 gr
	Diamètre interne de la cloche d'embrayage / Internal diameter of clutch bell	85.00 mm	maximum

Dessin de l'embrayage assemblé / Drawing of the clutch assembly

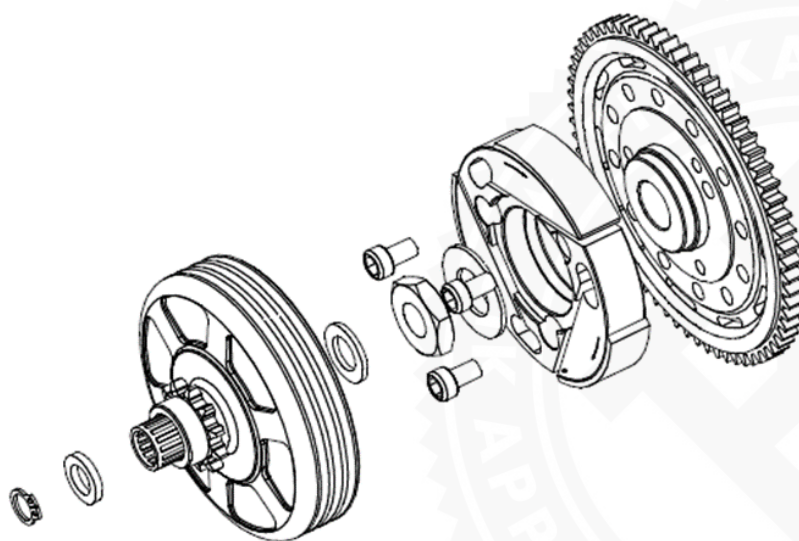

E

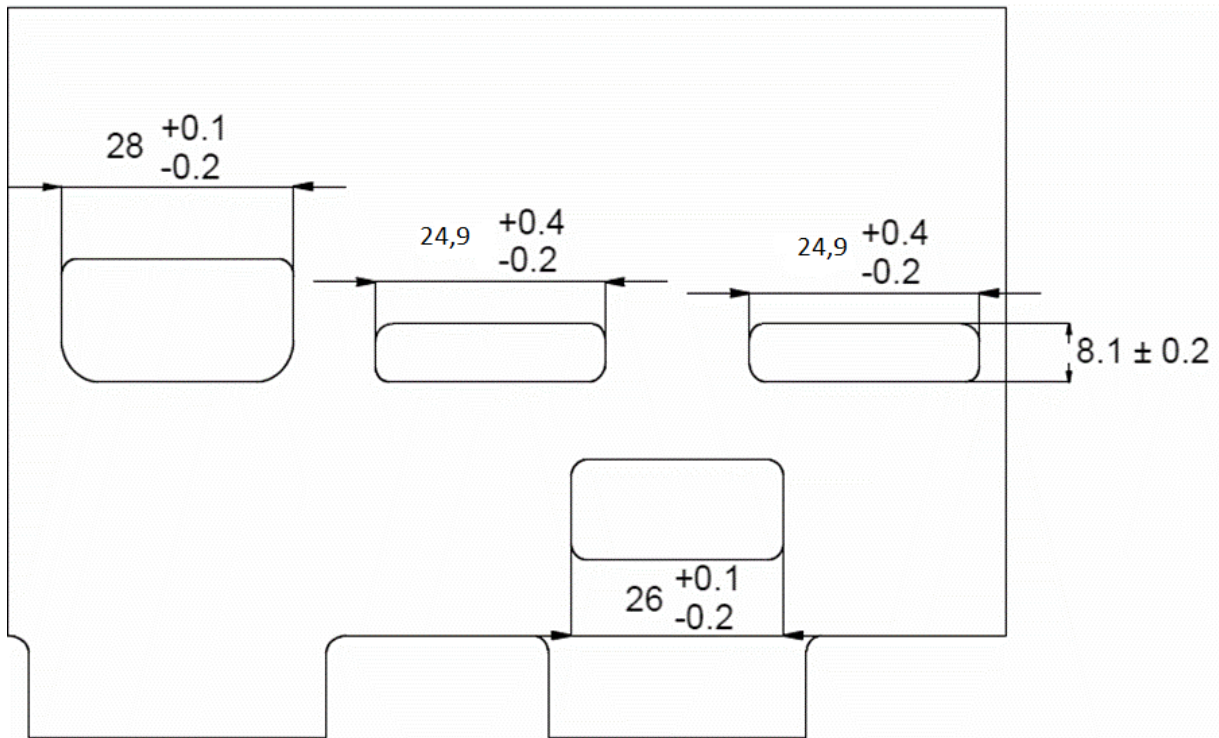
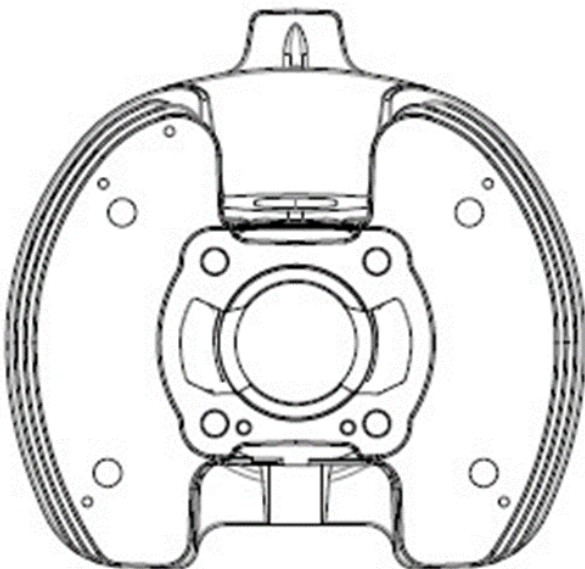
Photos, dessins et graphiques / *Photos, drawings and graphs*1. Cylindre / *Cylinder*Dessin du développement du cylindre (avec dimensions) / *Drawing of the cylinder development (with dimensions)*Dessin du pied du cylindre / *Drawing of the cylinder base*Photo du pied du cylindre / *Photo of the cylinder base*

Vue en coupe verticale du cylindre complet
(avec distance minimale de la surface d'appui du carburateur par rapport à l'axe du cylindre) /
Vertical cross section view of the complete cylinder
(with minimum distance of the carburettor support surface to cylinder axis)

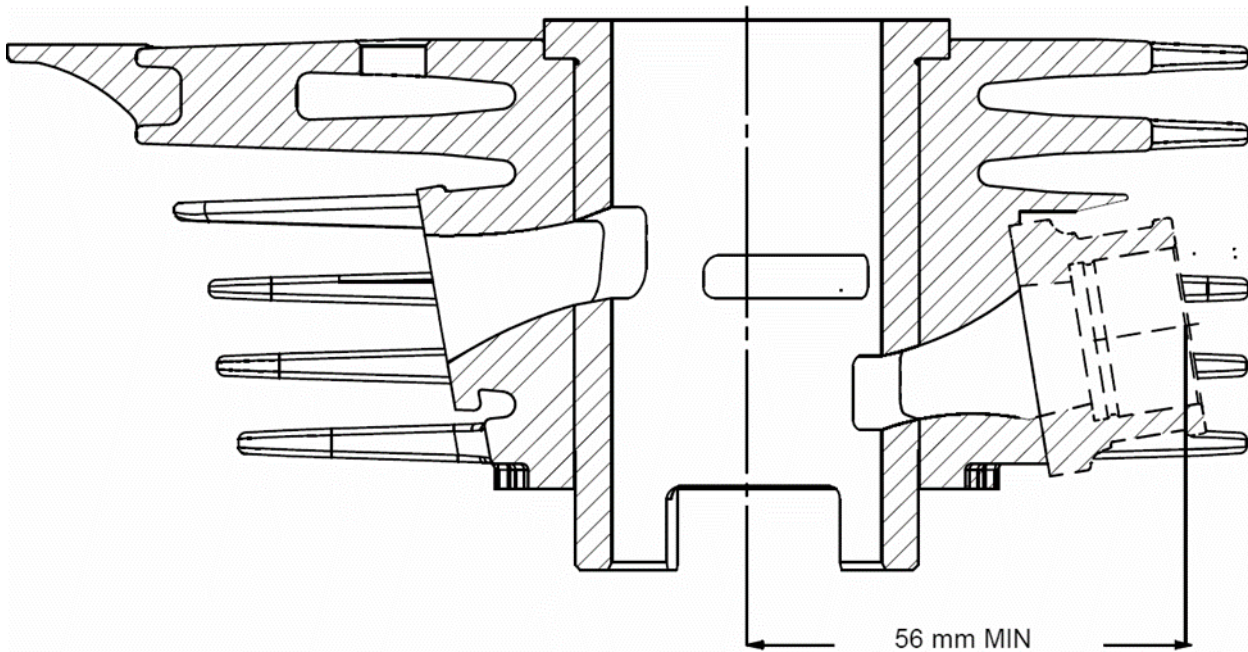

Dessin du collecteur d'échappement (dimensions principales avec tolérances) /
Drawing of exhaust manifold (main dimensions with tolerances)

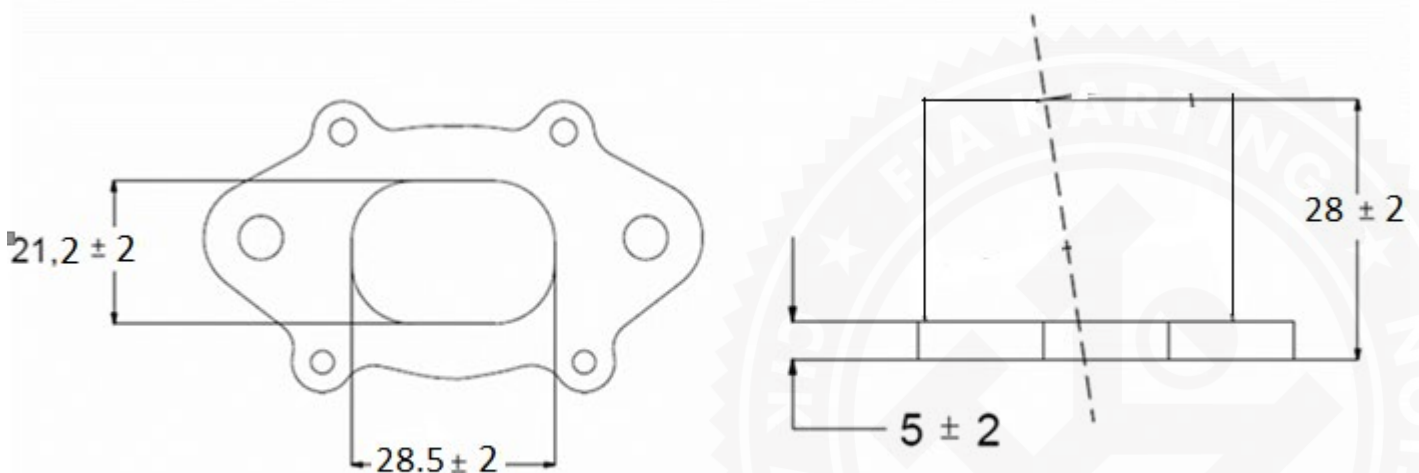

Dessin de la culasse et de la chambre de combustion (sans dimensions) /
Drawing of the cylinder head and the combustion chamber (without dimensions)

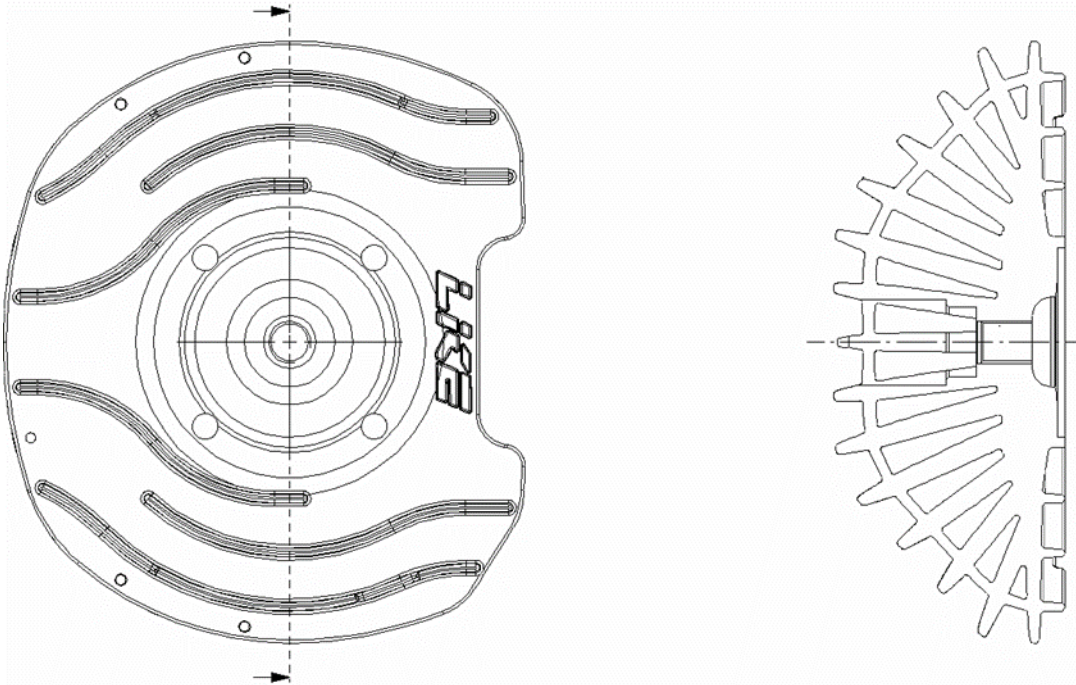
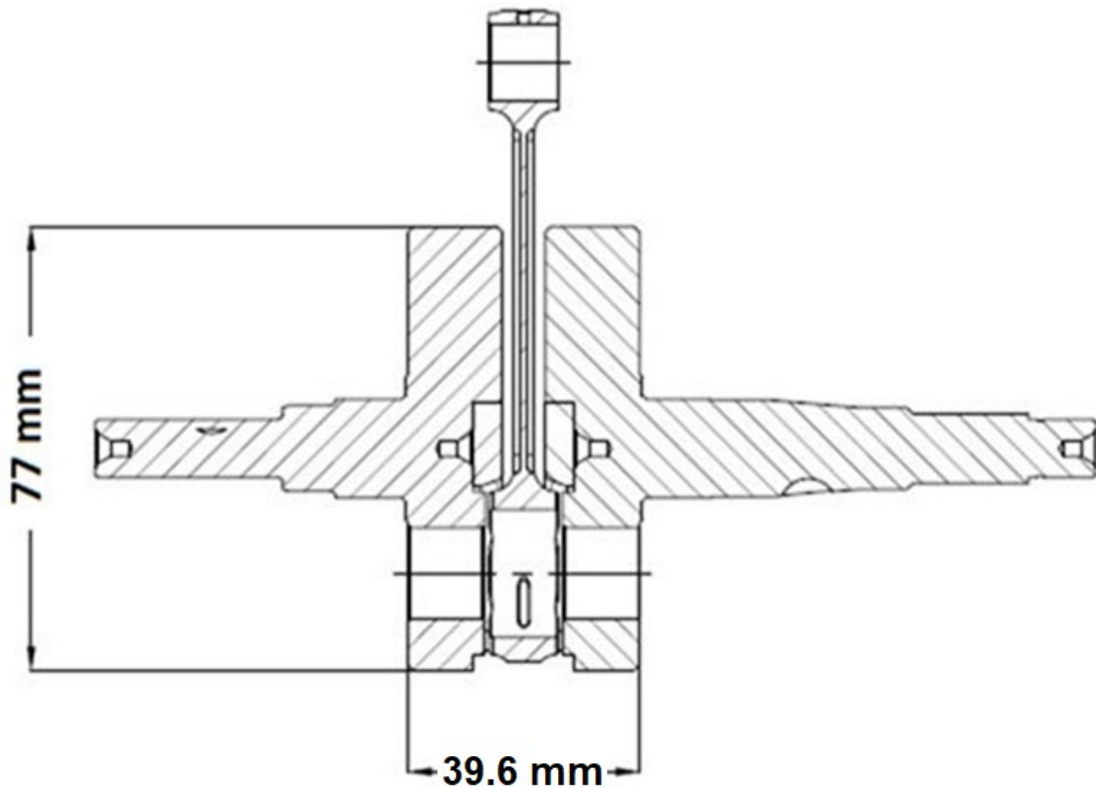

Photo de la culasse et de la chambre de combustion /
Photo of the cylinder head and the combustion chamber



2. Vilebrequin, bielle, piston et carter / Crankshaft, conrod, piston and crankcase

Dessin du vilebrequin complet (dimensions sans tolérances) /
Drawing of the complete crankshaft (dimensions without tolerances)



Photos de demi-vilebrequins (une avec contrepooids en plastique, une sans) /
Photos of crankshaft halves (one with plastic counterweight, one without)



Photo du vilebrequin et de la bielle /
Photo of the crankshaft and conrod

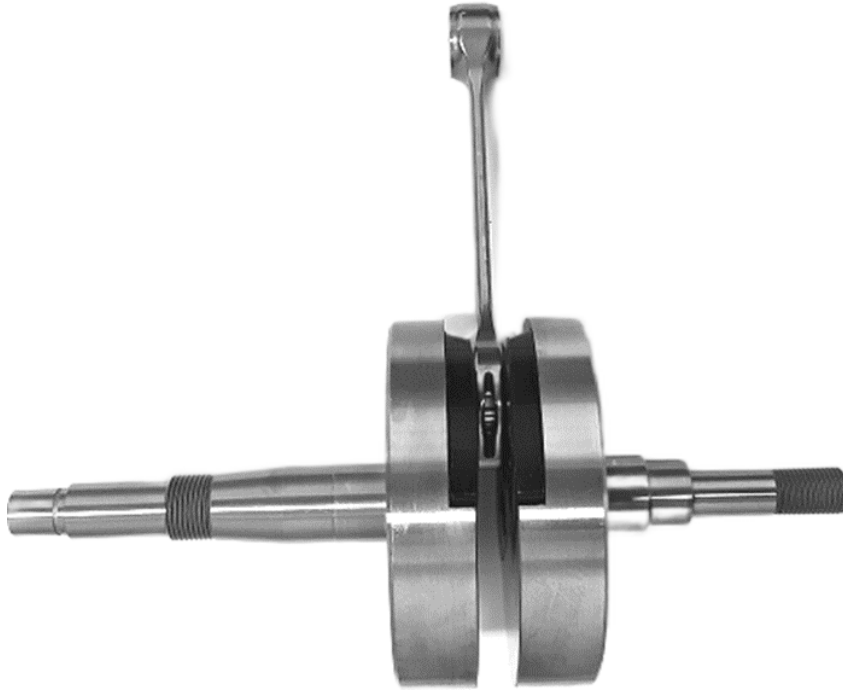

Photo de la bielle droite / *Photo of the conrod right*



Photo de la bielle gauche / *Photo of the conrod left*



Dessin du piston (dimensions principales sans tolérances et gabarit) /
Drawing of the piston (main dimensions without tolerances and template)

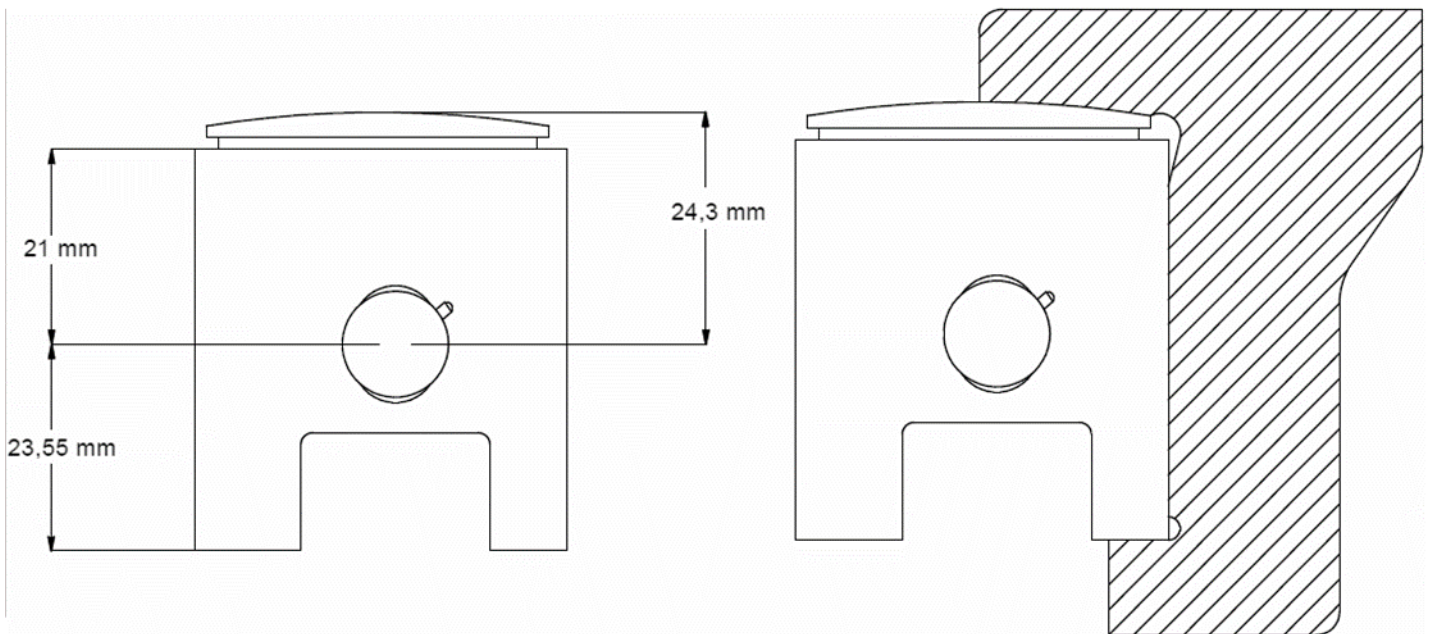

Photo du piston (de l'avant, de côté et d'en haut) / Photo of the piston (front, side and top)



Photo de l'intérieur du carter droit /
Photo of the inside of the right crankcase

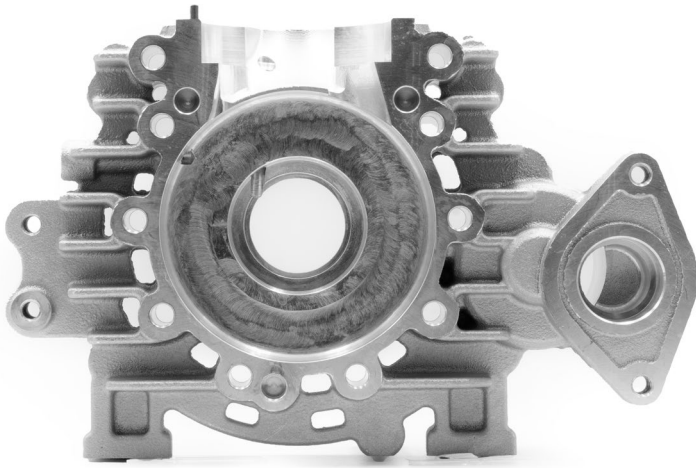

Photo de l'intérieur du carter gauche /
Photo of the inside of the left crankcase



Photo de l'extérieur du carter droit /
Photo of the outside of the right crankcase

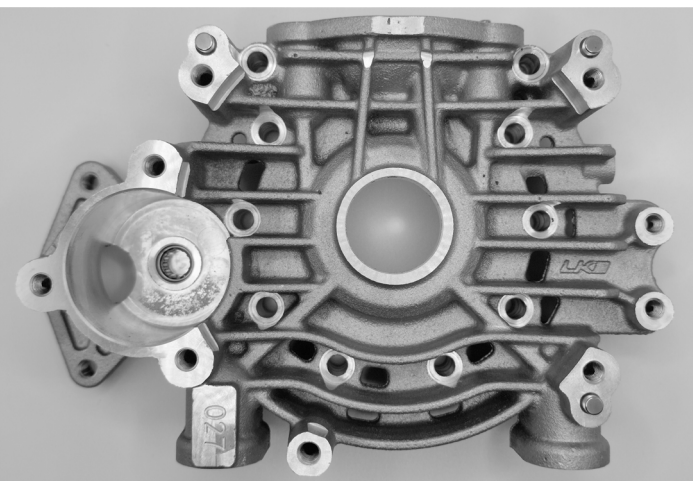
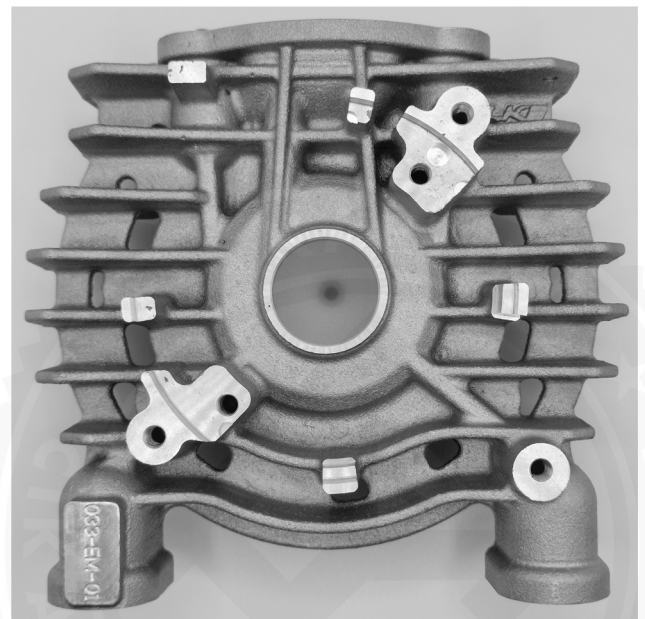

Photo de l'extérieur du carter gauche /
Photo of the outside of the left crankcase



3. Moteur / Engine

Photo du moteur côté pignon /
Photo of engine drive side

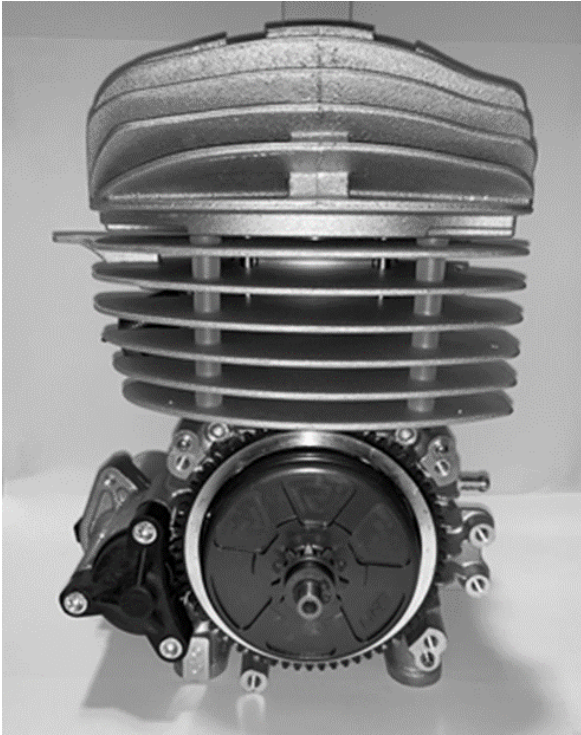

Photo du moteur côté opposé /
Photo of engine opposite side

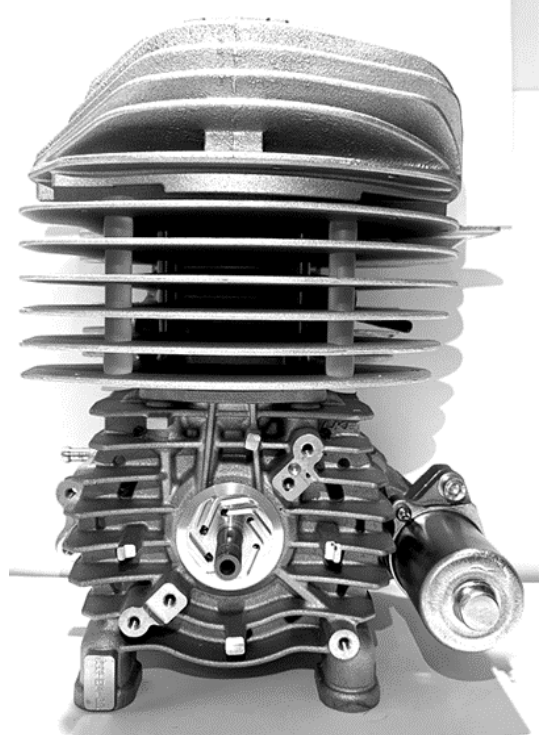

Photo du moteur complet vu de l'avant /
Photo of the complete engine front side



Photo du moteur complet vu de l'arrière /
Photo of the complete engine rear side

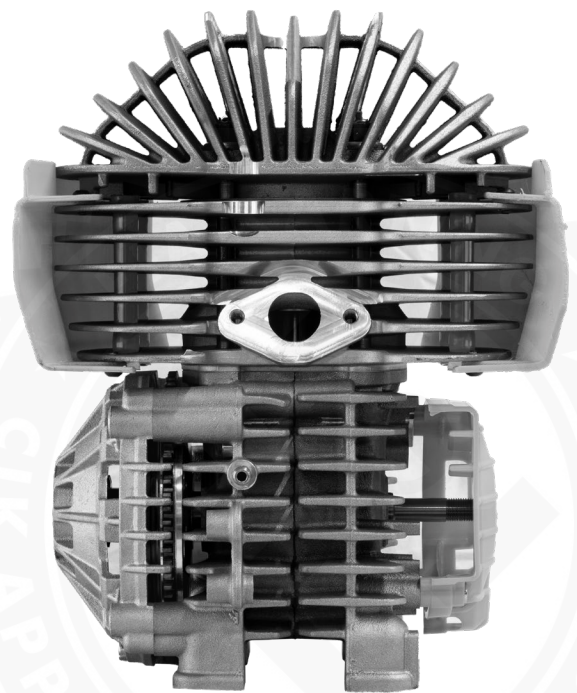

Photo du moteur complet vu du haut /
Photo of the complete engine taken from above



Photo du moteur complet vu du dessous /
Photo of the complete engine taken from below

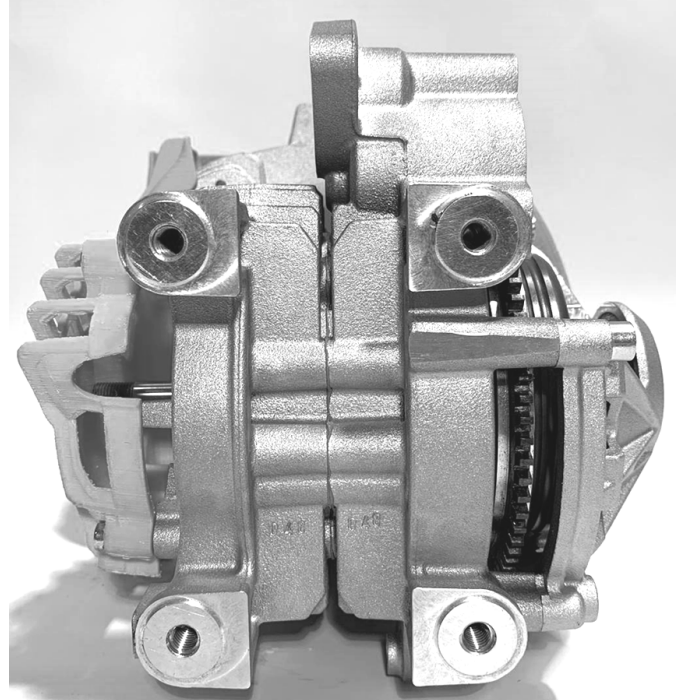

Photo des pièces plastiques du cylindre /
Photo of the cylinder plastic parts



Photo du protège-chaîne et du couvercle d'allumage /
Photo of the chain guard and ignition cover







F

Marquage des pièces principales / Main parts marking

Pour chaque pièce, photo d'ensemble avec le marquage et photo avec zoom sur le marquage /
For each part, overall photo with marking and zoomed photo of marking

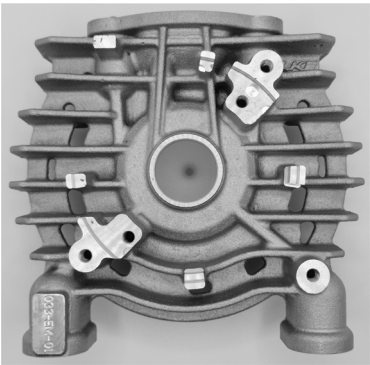
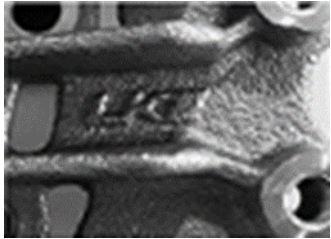
1. Fonderies des carters droit et gauche
2. Cylindre
3. Culasse
4. Chemise en fonte
5. Demi-vilebrequins
6. Bielle
7. Piston

1. Castings of LH & RH crankcases
2. Cylinder
3. Cylinder head
4. Cast iron liner
5. Half-crankshafts
6. Conrod
7. Piston

Pièces N° / Parts no.	Photo d'ensemble / Overall picture	Zoom
1		
2		
3		

4		
5		
6		
7		